

K&K Audio

RAKK dac

Mark III

Raleigh Audio

I2S Interface Products

Interface Specification and Installation Manual

Kit version

Use this manual with the following RAKK I2S interface products:

- RAKK I2S Receive board version 3.1 (single input)
- RAKK I2S Receive board version 4.1 (three input)
- RAKK I2S Send board version 2.2
- RAKK I2S Interface Adapter for Juli@ version 1.1

Required Tools and Supplies

35 to 50 Watt soldering iron

Diagonal cutting pliers

Long-nose pliers

Wire stripper

Solder

Warnings and Cautions

Caution – Use only solder that is intended for electrical circuits. Do not use acid or corrosive flux of any kind.

Support

RAKK dac and its associated components are produced through the joint cooperation of K&K Audio and Raleigh Audio. You may contact us with questions on constructing this kit by sending an e-mail message to david@raleighaudio.com or kevin@kandkaudio.com

Table of Contents

Preface	3
Introduction	4
Isolation and grounding	6
Implementation Instructions	8
PS Audio PWT Attachment	8
Generic CD Transport Attachment	8
Personal Computer or Music Server Attachment	8
I2S Interface Adapter Receive Board Installation Instructions	9
I2S Interface Adapter Send Board Installation Instructions	11
I2S Interface Adapter for Juli@ Card Installation Instructions	12
I2S Interface Adapter Receive Board Interface Specifications	14
Internal I2S interface	14
External I2S interface	14
Power Supply input	14
I2S Interface Adapter Send Board Interface Specifications	15
Internal I2S interface	15
External I2S interface	15
Power Supply input	15
I2S Interface Adapter for Juli@ Card Interface Specifications	16
Internal I2S interface	16
External I2S interface	16
Power Supply input	16
Parts List (Level B).....	17
Document version history.....	17
Parts Level History	17

Preface

For a digital interface to be defined, three aspects must be described: the logical, the electrical and the mechanical. The logical description tells how the data are encoded – for example, the number of signal and clock lines and how they relate. The electrical description outlines the structure – single ended or balanced – and the voltage, current and impedance of the circuit. The mechanical description covers the type of connector (if any) and how its pins are used.

The design of an interface is determined by the purpose of the interface; the Inter-IC Sound (I2S) interface was developed by Phillips for streaming digital audio between devices. As the name implies, a device was originally thought to be an Integrated Circuit (IC), usually on the same circuit board or between two boards in the same enclosure. Being an internal¹ interface, the number of lines used by the interface is not as critical as it is with an interface intended for communicating externally between two enclosures. Therefore three lines (one data and two clocks) were chosen for encoding the data. Because it is an internal interface, the ubiquitous TTL electrical specifications were chosen for the interface. Again, because it is an internal interface, there was no need to specify an external connector, so there is no mechanical definition.

For communicating externally between two enclosures, Phillips collaborated with Sony to develop the S/PDIF interface, which has a very different logical, electrical and mechanical specification from that of the I2S interface. Most significantly, since the numbers of lines are critical for an external interface, the data and timing are encoded onto a single line. Unfortunately, there is a trade-off to be made between the number of lines used by the interface and the jitter performance of the interface.

The superior performance of the I2S interface has enticed engineers to develop schemes to extend the function of the I2S interface so that it may be used externally between two enclosures. It is important to realize that there are no extensions to the Phillips I2S standard defined for external communication. All external I2S interfaces are proprietary ad-hoc solutions developed by companies for their own use and are different from each other.

To optimize the I2S interface for external communication between two enclosures, two aspects – the electrical and the mechanical – must be addressed. The electrical interface must be addressed because TTL technology demonstrates its best performance over very short distances within a single enclosure. Other technologies are typically used when a connection to an external device is needed. The mechanical aspect must be addressed simply because there is no I2S mechanical definition.

¹ For this document, “internal” means inside or within an enclosure or chassis; conversely, “external” means outside an enclosure or chassis.

Introduction

The RAKK I2S Interface suite of products provides the capability to attach a component, such as a CD transport or computer, to the RAKK dac Mark III using an external I2S interface. The various I2S boards contain circuitry to convert internal TTL level signals to external differential signals and vice versa.

The RAKK I2S Interface suite of products consists of four PC boards: a Send board, a single-input Receive board, a three-input Receive board and a daughter card for the ESI Juli@ PCI card. The four boards work together but all of the boards will not be present in any particular system. Rather, a combination of boards will be chosen to meet the needs of that particular system. The Send board resides in a CD transport and converts its internal TTL signals to external differential signals. The Juli@ PCI card with the RAKK I2S daughter card reside in a computer and converts its internal TTL signals to external differential signals. The Receive boards reside in the RAKK dac Mark III enclosure and convert the external differential signals to internal TTL signals used by the RAKK dac. The four boards are provided completely assembled, ready for installation.

There are several appropriate technologies for external digital interfaces. We found that the engineers at PS Audio had chosen Low Voltage Differential Signaling (LVDS) as the technology for interconnecting their superb PerfectWave products. It made sense for us to follow suit and use the interface that PS Audio had defined, including HDMI physical cables. By doing so, we can directly attach the PS Audio PerfectWave Transport (PWT) to the RAKK dac Mark III via a Receive board. In this case, the Send board is not used and no change of any kind is made to the PWT.

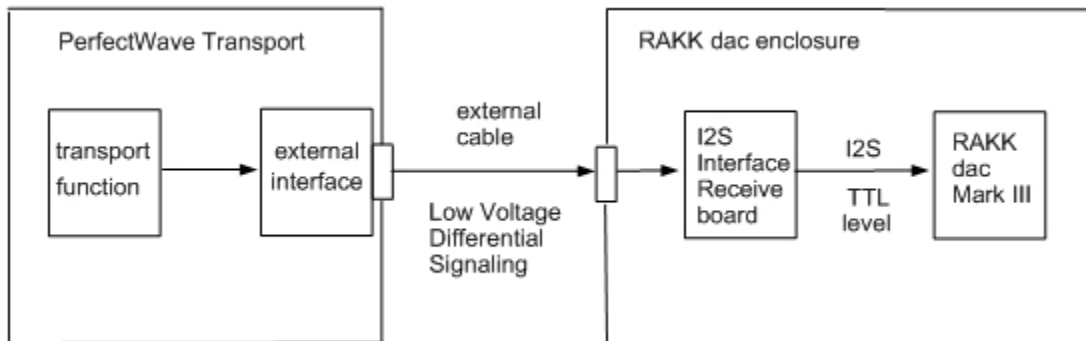

The RAKK I2S Interface Adapter for Juli@, together with the Juli@ PCI card, provides an external I2S interface for a personal computer.

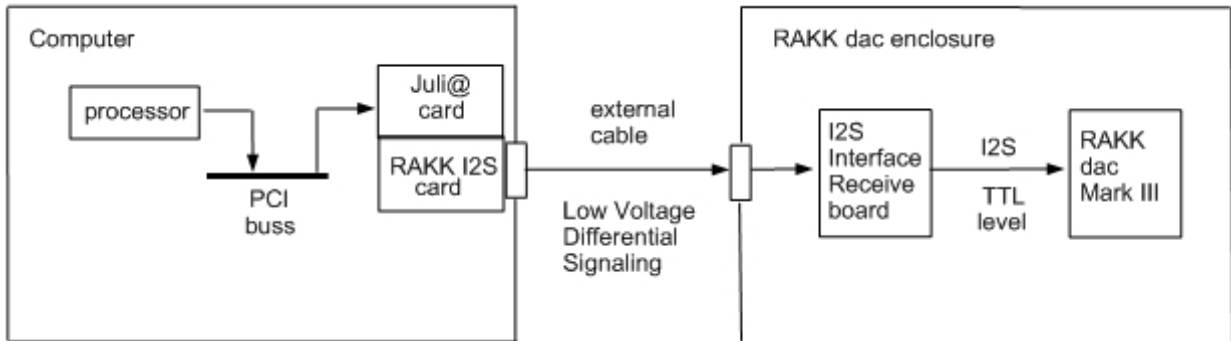

The RAKK I2S Send board provides an external I2S interface for a generic CD transport. The circuitry in the CD transport could be anything and we have no way of knowing about it. Therefore it is up to you to determine how to connect the Send board to the I2S signals in that device. Because of this, we strongly recommend that the Send board be used only by someone who has the necessary knowledge and skills to undertake the project without guidance.

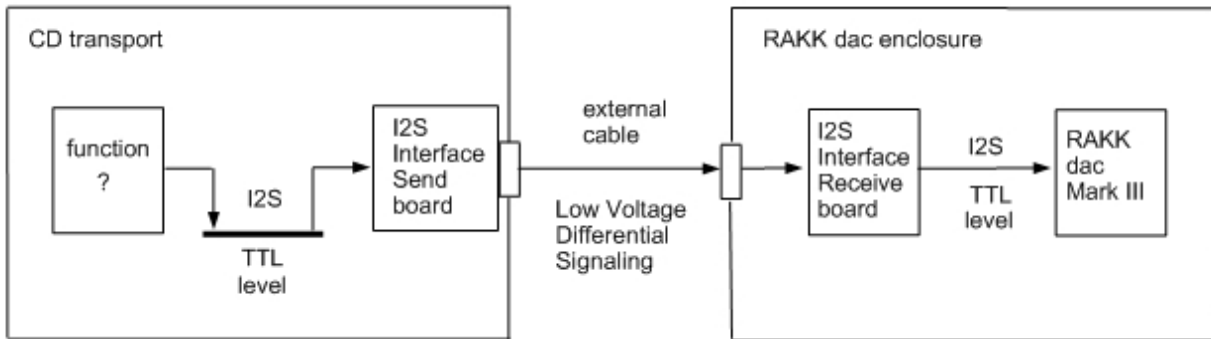

The RAKK three-input Receive board allows for the attachment and selection of up to three external I2S interfaces. Each of the three inputs is identical to the input on the single-input Receive board, so any combination of PWT, Juli@ card or Send board may be used.

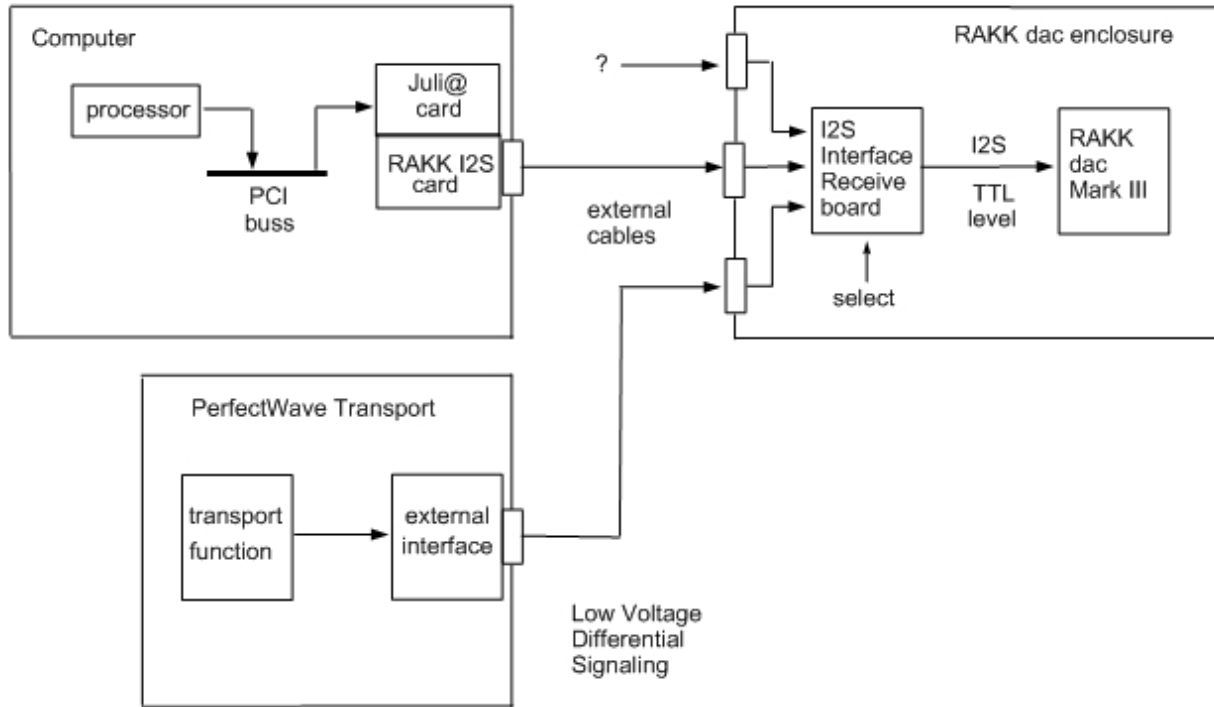

Isolation and grounding

For best performance, proper grounding practices must be followed in the system. This amounts to ensuring that ground references are provided where needed and that ground currents do not flow where they are not needed. We achieve this by a combination of isolation and careful routing of grounds. There are two potential problem areas – the power supply interface and the signal interface.

For the signal interface, we have chosen to provide a galvanically isolated I2S interface (both signal and ground) on the RAK dac Mark III. This prevents external ground current, potentially containing digital noise, from entering the RAKK dac ground system.

The I2S Receive boards do not have a galvanically isolated power supply interface. Rather, the preferred solution is to provide a totally separate DC power supply. This means a power supply derived from a separate power transformer or a separate (non-shared) winding on a power transformer. The RAKK dac Mark III version 2 Low Voltage Power System provides separate power supplies for the RAKK dac and the I2S Interface Adapter.

Now that the I2S interface Receive board and its power supply are completely isolated from the rest of the circuitry in the RAKK dac, the I2S circuitry is free to adopt the ground of the attaching device. This is fine and works well, however one problem remains. Since the I2S circuitry adopts the ground reference of the device that it is attached to, and does not have a ground reference of its own, the I2S circuitry is floating when it is not attached to another device. A floating ground will establish some undetermined voltage potential between it and the main ground structure. Then, when a connection is made to an attaching device (either by plugging in a cable or changing the select switch position), this voltage potential will discharge into the attaching device. In some cases this discharge has been shown to cause problems in the attaching device. Therefore provisions need to be made so as the I2S circuitry ground does not float with respect to the rest of the grounding structure.

Here is where things get to be a bit sticky – you want to isolate and connect at the same time. Let's take a closer look at the ground environment and what we hope to achieve. Good grounding practices dictate that digital devices, like computers, are plugged into a different mains branch circuit from the branch circuit that the analog devices are plugged into. So the digital grounds are on a different reference from the analog grounds – you don't want to connect these directly together. On the other hand, if you want to things to be at the same potential, they must be connected together. However, there is a solution.

That solution uses high impedance. Even though two grounds are interconnected, if they are interconnected through a high impedance, the noise current is limited. Even though there is a high impedance between the two grounds, the interconnection will allow the potential difference between the grounds to stabilize. They may not be at exactly the same potential, but they will be close. Moreover, the I2S circuitry ground will be at the same potential as the digital ground, which is what we want. Because the RAKK dac circuitry is galvanically isolated from the I2S circuitry, including ground and signal, it doesn't matter that there is a slight potential difference between the two grounds.

Each I2S input is grounded separately with a 1k Ω resistor connecting it to the chassis. Input grounds are not interconnected. For the three-input Receive board, resistor R4 is the grounding resistor for input 4, resistor R5 is the grounding resistor for input 5 and resistor R6 is the grounding resistor for input 6. Resistor R4 is the grounding resistor for the input on the single-input Receive board.

Implementation Instructions

PS Audio PWT Attachment

- Follow the Receive board installation instructions below.
- Connect the PWT to the RAKK dac enclosure using a standard HDMI cable.

Generic CD Transport Attachment

- Follow the Receive board installation instructions below.
- Follow the send board installation instructions below.
- Connect the CD transport to the RAKK dac enclosure using a standard HDMI cable.

Personal Computer or Music Server Attachment

- Follow the Receive board installation instructions below.
- Follow the Juli@ card installation instructions below.
- Connect the PC or music server to the RAKK dac enclosure using a standard HDMI cable.

I2S Interface Adapter Receive Board Installation Instructions

The I2S Receive boards are designed to be mounted to the RAKK dac Mark III board. These instructions assume that the Receive board will be used with the RAKK dac Mark III.

1. Complete the assembly of the RAKK dac Mark III.

2. Mount the receive board on the RAKK dac such that the I2S interface pads are co-located. Use four standoffs and screws.

3. Install six short wires between the I2S interface pads on the two boards. Observe polarity—the pads are aligned and labeled.

4. Mount the two boards in their location and secure them in place.

5. Install the internal ribbon cable(s).

6. Install a twisted pair of wires from the 5V power supply to the 5V pads on the I2S Receive board. Observe polarity. If you use the RAKK dac Mark III LVPS, refer to its manual for instructions.

7. Install a wire between the “chassis” pad on the I2S Receive board and the chassis at the point where the green-wire safety ground is connected to the chassis.

Skip the next two instructions if you have a single-input I2S Receive board.

8. Install a wire from the +12V pad on the power supply that is providing power to the RAKK dac to the +12V pad on the three-input I2S Receive board.
-

9. Install a twisted pair of wires from the input Select switch to the pads labeled “Input Select” 5 and 6 on the I2S Receive board. Observe the desired switch position for each wire.

There is no Input Select 4 pad on the I2S Receive board. Rather, input 4 is selected by default whenever either inputs 5 or 6 are not selected. Note that the operating contact of the Input Select switch is connected to the Input Select “com” pad on the RAKK dac. This is the ground for the +12V supply used in previous step above.

I2S Interface Adapter Send Board Installation Instructions

The Send board is designed to be mounted on the back panel on the CD transport with brackets holding the board. The brackets have been pre-assembled on the board to show how it should be mounted.

1. Measure the board assembly with the brackets to determine a hole drilling pattern.
-

2. Cut a hole in the back panel large enough to accept the HDMI connector.
-

3. Drill two holes for the screws.
-

4. Mount the Send board on the back panel and secure it in place with two screws.
-

5. Locate the internal TTL level I2S buss and determine an appropriate place to pick up the four signals. Install a wire for each of the signals, MCLK, SD, BCK and LRCK, to the labeled pads on the send board.

Note: the MCLK signal is not used by the RAKK dac.

6. Install a twisted pair of wires from the +5V and Ground pads on the send board to the 5V power supply. Observe polarity.
-

I2S Interface Adapter for Juli@ Card Installation Instructions

The I2S Interface Adapter for Juli@ card is designed to be mounted on the ESI Juli@ card in place of the analog card that is provided with the Juli@ card.

1. Following the directions in the Juli@ [User's Guide](#), remove the four screws securing the audio daughter card.
-

2. Detach the metal bracket from the card.
-

3. Following the directions in the Juli@ [User's Guide](#), carefully separate the PCI card from the audio daughter card.
-

4. Holding the Juli@ PCI card and RAKK I2S card by their edges, carefully plug them together.
-

5. Notice that the bracket will need to be modified for it to clear the HDMI connector on the RAKK I2S card. The HDMI connector has been positioned to bridge two of the holes in the bracket. The metal between the two holes will be removed so as to make room for the connector.

Position the bracket where it will be installed on the cards and mark the area on the bracket between the two holes covering the HDMI connector.

6. Using a tool such as a [Dremel tool](#), or a [nibble tool](#), or just a hand file, remove the material between the two holes that you have marked.

Move the circuit boards away from your work area for this step so as not to get metal chips on the boards.

7. Place the metal bracket in its location on the cards.

8. Install the four screws in the opposite order from which they were removed.

9. Remove power from the PC or music server.

10. Install the Juli@ card in the PC or music server.

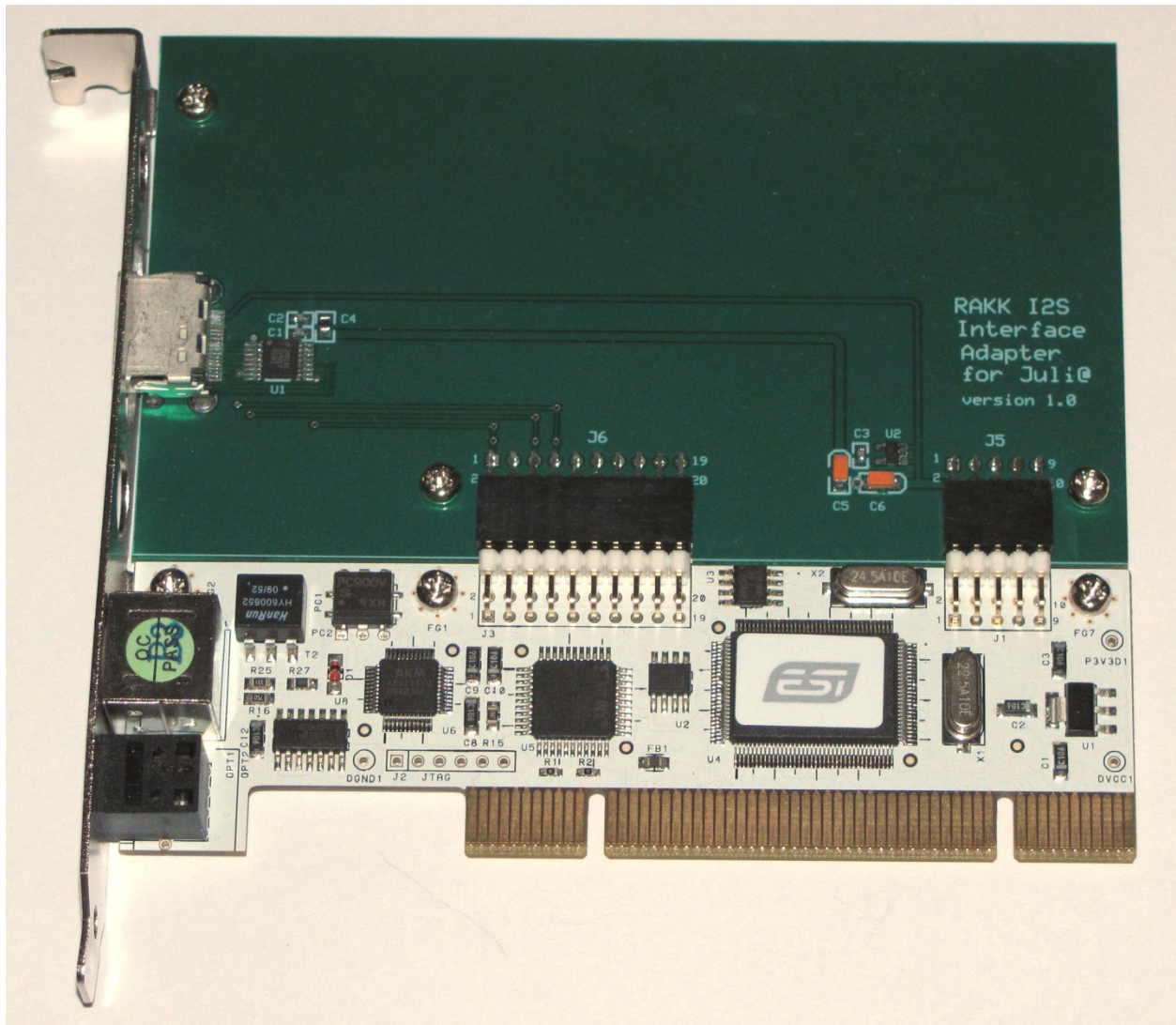

I2S Interface Adapter Receive Board Interface Specifications

Internal I2S interface

The I2S interface is galvanically isolated from the circuitry and ground on the RAKK dac board. Therefore all six wires must be connected for proper operation. The interface is implemented with a standard 3.3V logic family and is designed to operate into standard 3.3V or 5V logic families.

Electrical definition:

Nominal output pulse amplitude = 3.0V
Absolute minimum load impedance = 200Ω

External I2S interface

Electrical definition: The electrical interface is defined by the National Semiconductor [DS090LV032](#) LVDS differential Line Receiver.

Mechanical definition: The external interface uses the following pins on a standard HDMI connector:

Pin 1: Send Data (SD) –
Pin 2: Shield
Pin 3: Send Data (SD) +
Pin 4: Bit Clock (BCK) +
Pin 5: Shield
Pin 6: Bit Clock (BCK) –
Pin 7: Word Clock (LRCK) –
Pin 8: Shield
Pin 9: Word Clock (LRCK) +
Pin 17: Ground

- The Shields on pins 2, 5 and 8 are connected to ground.
- The Ground on pin 17 provides a ground reference for the circuitry on the Receive board.

Power Supply input

The version 3, single-input Receive board requires +5V at 30mA.
The version 4, three-input Receive board requires +5V at 50mA.
For best performance, this 5V power supply should be galvanically isolated from the RAKK dac 12V power supply. This, together with the isolated I2S interface on the RAKK dac Mark III will provide isolation between the RAKK dac and the attaching device.

The version 4, three-input Receive board requires +12V at 25mA.
This voltage must be provided by a power supply that shares a common ground with the RAKK dac 12V power supply. It may be the same supply.

I2S Interface Adapter Send Board Interface Specifications

Internal I2S interface

The I2S signals are referenced to power ground. The interface is implemented with a standard 3.3V logic family and is designed to operate with standard 3.3V or 5V logic families.

External I2S interface

Electrical definition: The electrical interface is defined by the National Semiconductor [DS090LV031](#) LVDS differential Line Driver.

Mechanical definition: The interface uses the following pins on a standard HDMI connector:

Pin 1: Send Data (SD) –
Pin 2: Shield
Pin 3: Send Data (SD) +
Pin 4: Bit Clock (BCK) +
Pin 5: Shield
Pin 6: Bit Clock (BCK) –
Pin 7: Word Clock (LRCK) –
Pin 8: Shield
Pin 9: Word Clock (LRCK) +
Pin 10: Master Clock (MCLK) +
Pin 11: Shield
Pin 12: Master Clock (MCLK) –
Pin 17: Ground
Pin 19: Hot Plug Detect

- The Shields on pins 2, 5, 8 and 11 are connected to ground.
- The Hot Plug Detect on pin 19 is connected to ground.
- The Ground on pin 17 is connected to the power ground of the housing component. This Ground, carried through the cable, provides the ground reference for the Receive board.
- The RAKK I2S Receive board does not use the MCLK signals or the Hot Plug Detect.

Power Supply input

The Send board requires +5V at 20mA.

I2S Interface Adapter for Juli@ Card Interface Specifications

Internal I2S interface

The I2S signals are referenced to power ground. The interface is implemented with a standard 3.3V logic family and is designed to operate with standard 3.3V or 5V logic families.

External I2S interface

Electrical definition: The electrical interface is defined by the National Semiconductor [DS090LV031](#) LVDS differential Line Driver.

Mechanical definition: The interface uses the following pins on a standard HDMI connector:

Pin 1: Send Data (SD) –
Pin 2: Shield
Pin 3: Send Data (SD) +
Pin 4: Bit Clock (BCK) +
Pin 5: Shield
Pin 6: Bit Clock (BCK) –
Pin 7: Word Clock (LRCK) –
Pin 8: Shield
Pin 9: Word Clock (LRCK) +
Pin 10: Master Clock (MCLK) +
Pin 11: Shield
Pin 12: Master Clock (MCLK) -
Pin 17: Ground
Pin 19: Hot Plug Detect

- The Shields on pins 2, 5, 8 and 11 are connected to ground.
- The Hot Plug Detect on pin 19 is connected to ground.
- The Ground on pin 17 is connected to the power ground of the housing component. This Ground, carried through the cable, provides the ground reference for the Receive board.
- The RAKK I2S Receive board does not use the MCLK signals or the Hot Plug Detect.

Power Supply input

The RAKK I2S card for Juli@ requires +5V at 20mA.

Parts List (Level B)

Designator	Part	Description	Qty
	bracket with screws	mounted on Send board	2

Document version history

Document	Description
1.0	Original document Intended to support parts version 1
2.0	Intended to support parts version 2, level A
2.1	Document only update of power requirements. Include instructions for LED potentiometer.
2.2	Document only update. Clarification for Extreme RAKK dac build.
2.3	Document only update. Include instructions for grounding.
2.4	Document only update. Clarify instructions for grounding.
3.0	Major revision to support: <ul style="list-style-type: none"> • RAKK I2S Receive board version 3.1 (single input) • RAKK I2S Receive board version 4.1 (three input) • RAKK I2S Send board version 2.2 • RAKK I2S Interface Adapter for Juli@ version 1.1
3.1	(this document) Document only update. Clarification of instructions for Send Board.

Parts Level History

Version	Level	Description
1		Original level
2	A	<ul style="list-style-type: none"> • Removed DC – DC convertor from receive board power supply • Provided optional power isolation • Added brackets to send board • Cosmetic labeling changes
2	B	<ul style="list-style-type: none"> • Add 2K potentiometer
3	B	All parts removed except for brackets and screws for the Send board.